

Heckturoeffnung 90°/180°
 (rear door opening)
 Sonderausrustung 260°
 (optional equipment)

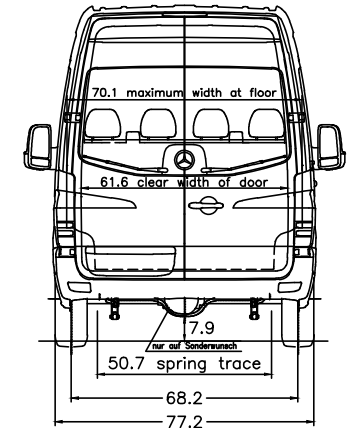

Important notes:

- It is the responsibility of the bodybuilder to ensure that the vehicle is suitable for homologation after the body has been mounted.
- The drawing is simplified to some extent and is not legally binding. For more details and further explanations please see the MBAC-Web User Guide in the bodybuilder portal.
- Please check whether the drawing specification complies with the chassis configuration of your order.
- Optional equipment codes not listed here, KW-codes and changes resulting from feasibility checks (BBA) are not included in the drawing.

MHD Engine low-emission EPA 14/CARB
 R08 Tyres LT 245/70 R16
 R04 Adjustable rear-view seat
 T16 Sliding door right
 U02 Seating comp. 3-seat bench 1st row narrow
 U03 Pass. comp. seating, 3-seater bench/narrow 2nd row
 U04 Passenger seats, 4-seater bench 3rd row
 X02 Higher weight 3,800 kg
 X00 Front
 Z04 Crewcab

D03 High roof
 D03 High roof
 D02 Sprinter standard
 R08 Wheelbase 3205 mm, overhang 1810 mm
 M03 Engine 601 DE 2.2 LA 120 kW (163 hp) 3000 rpm

Dimensions refer to the standard version. Measurements of body vehicle.

All dimensions refer to the standard version. Measurements of body vehicle.

Our instructions for the manufacture of superstructures must be observed, when planning to fit bodies of other than Mercedes-Benz manufacturer.

Dimensions are subject to a tolerance of up to +/- 3%.

Passenger Van

Abt. (Dept.) TE/SOD
 70546 Stuttgart

2500/4x2/170.3
 HVA 9061000301

vehicle type :	loading space =	494 cu.ft.	H		G										
				unladen	unladen		α°	β°	δ°						
906.735-13	79.7 sq.ft.		23.6	25.6	106.9	18	12	13							
tyres	245/75R16 245/75R16	gross vehicle weight	GW (t)	FA (t)	RA (t)										
			1759	816											

2023 Date Order no. 2023 Date Order no.